

## KNIFE GATE VALVE – VGU01U (Rev. 02/2021)

### Quality

- ISO 9001 Certificated Company
- CRCC Petrobras Certification and Qualification of Company and Products

### Main Features

- Function: On/off
- Construction: MSS-SP 81
- Type: Wafer and Semi LUG
- Size: 2" (50mm) to 32" (800mm)
- Flow: Bidirectional
- 100% Tightness
- High performance with full and coated passage

### General Application

- Mining, Steel Industry, etc
- Processes with abrasive and corrosive liquids, ore slurry and similar

### Maximum Pressure (Temperature between 0°C to 70°C)

DN	in.	2"	2½"	3"	4"	5"	6"	8"	10"	12"	14"	16"	18"	20"	24"	28"	32"
	mm	50	65	80	100	125	150	200	250	300	350	400	450	500	600	700	800
CWP(bar)		10	10	10	10	10	10	8	6	6	6	6	4	4	4	4	4

### Maximum Temperature

EPDM (°C)	NATURAL RUBBER (°C)	PE (°C)
-10 to 110	-30 to 70	-269 to 90

### Internal Inspection and Testing (FKB Factory)

- **Hidrostatic:** ISO 5208 GR 3
- **Performance:** FKB Standard (a complete cycle)
- **Painting:** FKB Standard and NBR 14847
- **Visual:** FKB Standard and NBR 15185 / MSS-SP-25
- **Dimensional:** according to MSS-SP 81

### Flange / Connection

- ANSI B16.5 – 150lbs
- DIN PN10 / NBR 7675 PN10
- Others on request

### Types of Drives

- Manual Steering Wheel
- Gear Box
- Pneumatic Actuator
- Hydraulic Actuator
- Electric Actuator

### Optional Accessories

- Solenoid Valve
- Limit Switch
- Lubrifil Kit
- External Stem Protection
- Others

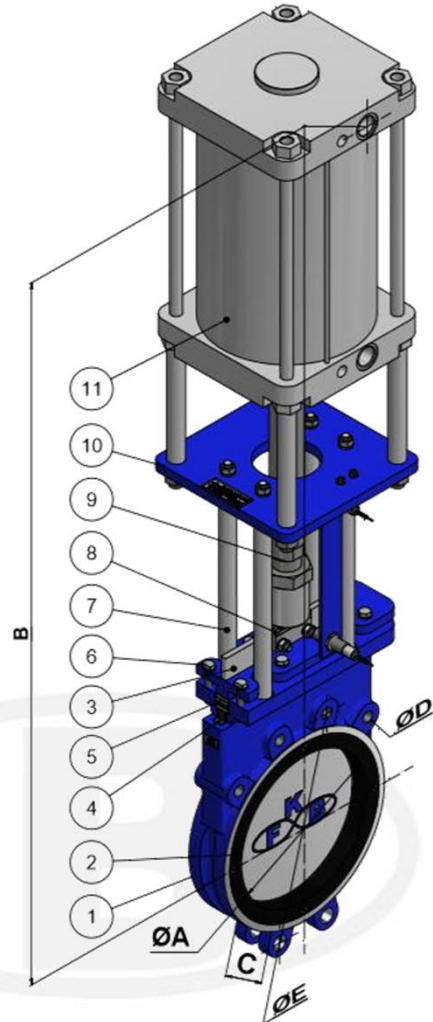

### Material Table

Pos.	Description	Material
1	Monoblock Body	ASTM A536 / ASTM A216 WCB / ASTM A 351 CF8 / ASTM A 351 CF8M
2	Coating Ring	Polyethylene
3	Gate	AISI 316
4	Perimeter Sealing	Natural Rubber / EPDM (*)
5	Superior Sealing	Synthetic Fiber with PTFE
6	Packing Preme Screws	Carbon Steel or Stainless Steel
7	Support / Column	SAE 1020
8	Fork / Stem Nut	AISI 304 / Brass
9	Stem	AISI 410
10	Table	ASTM A36
11	Drive	Manual or Automatic

(\*) other options on request

### Dimensions Table

A		B (*)		C		DIN PN 1 0		ANSI B16.5 1 50 lbs	
in.	mm	mm	mm	QTD - ØM	mm	QTD - ØM	inches	inches	inches
2"	50	455,0	47,75	04 - M16	125	04 - ½" UNC	4. ¾"		
2½"	65	534,3	47,75	04 - M16	145	04 - ½" UNC	5. ½"		
3"	80	600,2	50,80	08 - M16	160	04 - ½" UNC	6"		
4"	100	669,9	50,80	08 - M16	180	08 - ¾" UNC	7. ½"		
5"	125	714,0	57,15	08 - M16	210	08 - ¾" UNC	8. ½"		
6"	150	818,0	57,15	08 - M20	240	08 - ¾" UNC	9. ½"		
8"	200	1.051,0	69,85	08 - M20	295	08 - ¾" UNC	11. ¾"		
10"	250	1.216,1	69,85	12 - M20	350	12 - ¾" UNC	14. ¼"		
12"	300	1.272,6	76,20	12 - M20	400	12 - ¾" UNC	17"		
14"	350	1.421,5	76,20	16 - M20	460	12 - 1" UNC	18. ¾"		
16"	400	1.603,0	88,90	16 - M24	515	16 - 1" UNC	21. ¼"		
18"	450	1.702,3	88,90	20 - M24	565	16 - 1½" UNC	22. ¾"		
20"	500	1.876,5	114,30	20 - M24	620	20 - 1½" UNC	25"		
24"	600	2.156,4	114,30	20 - M27	725	20 - 1½" UNC	29. ½"		
28"	700	2.530,8	117,30	24 - M27	840	28 - 1½" UNC	34"		
32"	800	2.764,8	117,30	24 - M30	950	28 - 1½" UNC	38. ½"		

### Notes:

1. (\*) Measure "B" under consultation for other types of drives;
2. Measures subject to change without notice.

Read More: [vendas@fkbalvulas.com.br](mailto:vendas@fkbalvulas.com.br)