

## KNIFE GATE VALVE – VGU32 (Rev. 02/2021)

### Quality

- ISO 9001 Certificated Company
- CRC Petrobras Certification and Qualification of Company and Products
- ONIP Certificated Company

### Main Features

- Function: On/off
- Construction: MSS-SP 81
- Type: Wafer and Semi LUG
- Size: 2" (50mm) to 32" (800mm) (\*)
- Flow: Bidirectional with preferential side
- 100% Tightness
- Double sealing system
- Rings that cover the passage protecting the body
- High performance with full and coated passage
- Cleaning system attached to the valve body

### General Application

- Processes with liquids that have fouling and / or solidification characteristics
- Petrochemicals, Food, Pulp and Paper, Wastewater treatment plants, etc.

### Maximum Pressure (Temperature between 0°C to 70°C)

DN	In.	2"	2½"	3"	4"	5"	6"	8"	10"	12"	14"	16"	18"	20"	24"	28"	32"
	mm	50	65	80	100	125	150	200	250	300	350	400	450	500	600	700	800
	CWP(bar)	10	10	10	10	10	10	8	6	6	6	6	4	4	4	4	4

### Maximum Temperature

EPDM (°C)	METAL (°C)	PTFE (°C)	VITON (°C)
-10 to 110	High Temperature	-20 to 180	-30 to 200

### Internal Inspection and Testing (FKB Factory)

- **Hidrostatic:** ISO 5208 GR 3
- **Performance:** FKB Standard (a complete cycle)
- **Painting:** FKB Standard and NBR 14847
- **Visual:** FKB Standard and NBR 15185 / MSS-SP-25
- **Dimensional:** according to MSS-SP 81

### Flange / Connection

- ANSI B16.5 – 150lbs
- DIN PN10
- Others on request

### Types of Drives

- Manual Steering Wheel
- Gear Box
- Pneumatic Actuator
- Hydraulic Actuator
- Electric Actuator

### Optional Accessories

- Solenoid Valve
- Limit Switch
- Lubrifi Kit
- External Stem Protection
- Others

### Material Table

Pos.	Description	Material
1	Monoblock Body	ASTM A536 / ASTM A216 WCB / ASTM A 351 CF8 / ASTM A 351 CF8M
2	Connections (Cleaning System)	AISI 304 / AISI 316 / ASTM A36 / Brass
3	Tubbing (Cleaning System)	AISI 304 / AISI 316 / Corrosion resistant plastic (*)
4	Coating Ring	ASTM A216 WCB / ASTM A 351 CF8 / ASTM A 351 CF8M
5	Passage Sealing	PTFE + Metal - Metal / VITON + Metal - Metal / EPDM + Metal - Metal / Metal - Metal
6	Superior Sealing	Synthetic Fiber with PTFE (*)
7	Packing Preme Screws	Carbon Steel / Stainless Steel
8	Gate	AISI 304 / AISI 316
9	Fork / Stem Nut	Stainless Steel / Brass
10	Stem	AISI 410
11	Column / Support	Carbon Steel
12	Drive	Manual or Automatic

(\*) other options on request

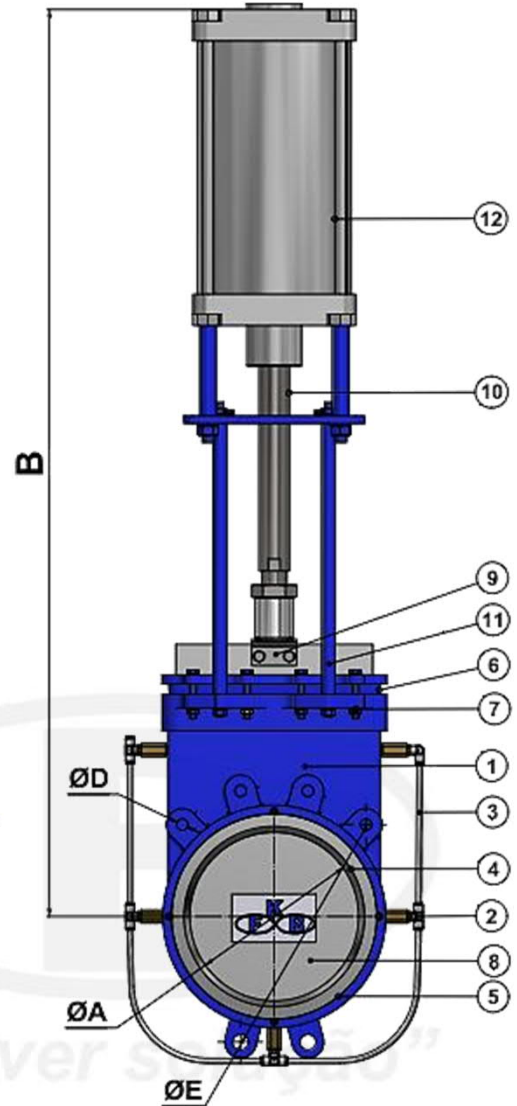

### Dimensions Table

		DIN PN 10			ANSI B16.5 150 lbs		
	A	B (*)	C	ØD	ØE	ØD	ØE
In.	mm	mm	mm	QTD - ØM	mm	QTD - ØM	Inches
2"	50	546,0	47,75	04 - M16	125	04 - ½" UNC	4. ¾"
2½"	65	641,0	47,75	04 - M16	145	04 - ½" UNC	5. ½"
3"	80	720,0	50,80	08 - M16	160	04 - ½" UNC	6"
4"	100	803,0	50,80	08 - M16	180	08 - ¾" UNC	7. ½"
5"	125	918,5	57,15	08 - M16	210	08 - ¾" UNC	8. ½"
6"	150	1.049,0	57,15	08 - M20	240	08 - ¾" UNC	9. ½"
8"	200	1.130,6	69,85	08 - M20	295	08 - ¾" UNC	11. ¾"
10"	250	1.125,0	69,85	12 - M20	350	12 - ¾" UNC	14. ¼"
12"	300	1.272,6	76,20	12 - M20	400	12 - ¾" UNC	17"
14"	350	1.446,0	76,20	16 - M20	460	12 - 1" UNC	18. ¾"
16"	400	1.614,0	88,90	16 - M24	515	16 - 1" UNC	21. ¼"
18"	450	1.830,0	88,90	20 - M24	565	16 - 1 ½" UNC	22. ¾"
20"	500	1.985,0	114,30	20 - M24	620	20 - 1 ½" UNC	25"
24"	600	2.298,0	114,30	20 - M27	725	20 - 1 ½" UNC	29. ½"
28"	700	2.656,0	117,30	24 - M27	840	28 - 1 ½" UNC	34"
32"	800	3.025,0	117,30	24 - M30	950	28 - 1 ½" UNC	38. ½"

Notes:  
1. (\*) Measure "B" under consultation for other types of drives;  
2. Measures subject to change without notice.

Read More: [vendas@fkbvalvulas.com.br](mailto:vendas@fkbvalvulas.com.br)

FKB INDÚSTRIA DE EQUIPAMENTOS LTDA.

Estrada do Akama, 1300 – Lambari | Guararema – SP | CEP 08900-000

Tel: +55 11 4693-2042 | [www.fkbvalvulas.com.br](http://www.fkbvalvulas.com.br)