

## DIVERTER VALVE (3 OUTPUTS) - VD03 (Rev. 06/2021)

### Quality

- ISO 9001 Certificated Company
- CRCC Petrobras Certification and Qualification of Company and Products
- ONIP Certification

### Main Features

- Function: To divert a material from one direction to another through gravitational flow
- Build: API and FKB Standard
- Type: Flanged
- Size: 6" (150mm) to 36" (900mm) (\*)
- Flow: Unidirectional
- 100% tightness
- Flange: Circular, Square or Rectangular;

### General Application

Processes with fines in general, coal fines, coal in fragments, granules in general, sugar, salt, abrasives, corrosives, sanitary and similar.

### Temperatura máxima

EPDM (°C)	UHMW (°C)	PTFE (°C)	VITON (°C)
-10 to 110	-269 to 90	-20 to 180	-30 to 200

### Internal Inspection and Testing (FKB Factory)

- **Hydrostatic:** ISO 5208 GR 3
- **Performance:** FKB Standard (a complete cycle)
- **Painting:** FKB Standard and NBR 14847
- **Visual:** FKB Standard and NBR 15185 / MSS-SP-25
- **Dimensional:** according project

### Flange / Connection

- ANSI B16.5 – 150lbs
- DIN PN10
- Others on request

### Optional Accessories

- Solenoid Valve
- Limit Switch
- Lubrifil Kit
- Others

### Types of Drives

- Lever
- Pneumatic Actuator
- Hydraulic Actuator
- Electric Actuator

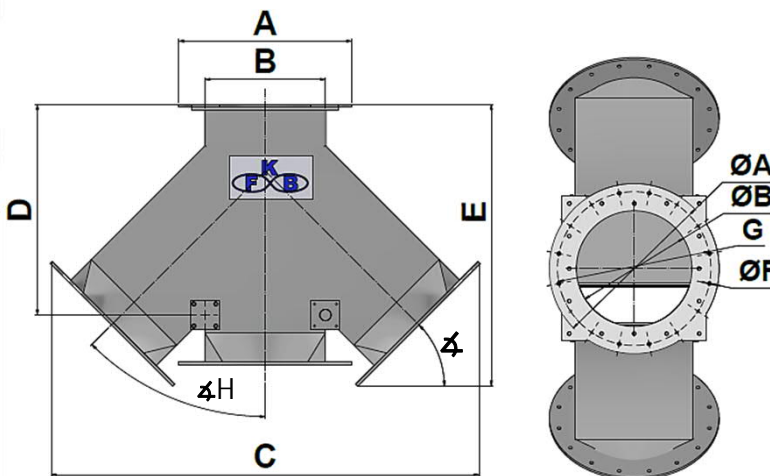
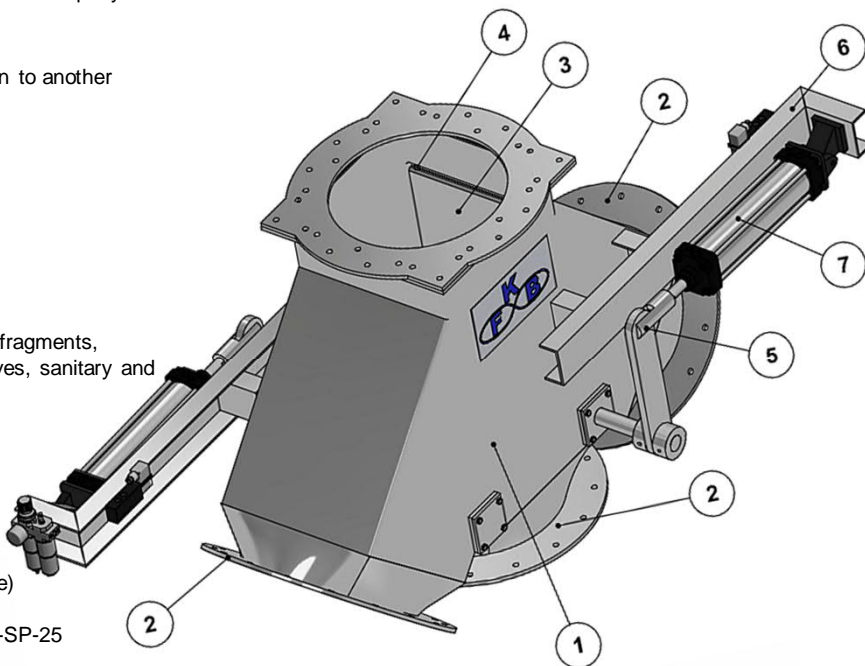

### Material Table

Pos.	Description	Material
1	Body	ASTM A240 TP 304 / ASTM A240 TP 316 / ASTM A36 with coating
2	Flange	ASTM A240 TP 304 / ASTM A240 TP 316 / ASTM A36 with coating
3	Knife	ASTM A240 TP 304 / ASTM A240 TP 316 / ASTM A36 with coating
4	Face Sealing	EPDM/ VITON / UHMW / PTFE (*)
5	Bolts and Nuts	AISI 304 / AISI 3016 / Carbon Steel
6	Actuator Support	ASTM A240 TP 304 / ASTM A240 TP 316 / ASTM A36 with coating
7	Drive	Manual (Lever) or Automatic

(\*) Other options on request

### Dimensions Table

SQUARE PASSAGE		CIRCLE PASSAGE		DIMENSIONS			DRILLING	DRILLING CENTER	ANGLE
Side 1	Side 2	ØA	ØB	C	D	E	ØF	G	∠H
mm	mm	mm	mm	mm	mm	mm			

Learn More: [vendas@fkbalvulas.com.br](mailto:vendas@fkbalvulas.com.br)

FKB INDÚSTRIA DE EQUIPAMENTOS LTDA.  
 Estrada do Akama, 1300 – Lambari | Guararema – SP | CEP 08900-000  
 Tel: +55 11 4693-2042 | [www.fkbalvulas.com.br](http://www.fkbalvulas.com.br)